

Type SB6 Load Cell



Flintec load cells are designed to meet the most stringent accuracy requirements. Certifications have been obtained from Weights & Measures Authorities, worldwide.

SB6 load cells are available in the capacities 0.2 kN to 2 kN (20.4 kg to 204 kg) and include Accuracy Classifications GP, C1, C3 and C3 MR according to OIML R 60.

They offer total stainless steel construction and complete hermetic sealing, making them suitable for use in the toughest industrial environments.

The special loading hole combined with the available Flintec loading hardware provides an excellent price-performance ratio.

It allows very low profile platform design and offers advantages in all kinds of weighing applications.

The Flintec calibration technique (in mV/V/Ω) eliminates time consuming corner calibration in multiple load cell systems.

Important Features

- Capacities: 0.2 kN to 2 kN.
- High accuracy.
- Total stainless steel construction.
- Complete hermetic sealing.
- Protection IP 68.
- Low profile.
- High input resistance: 1100 Ω.
- W&M certified for 3000 intervals.
- Multi range accuracy.
- Calibration in mV/V/Ω.
- Easy cable replacement.
- Complete range of loading hardware available.
- Factory mutual approved.

Option

- Explosion proof EEx ia IIC T6...T4.

SB6 Specifications

Maximum capacity (=E _{max})	kN	0.2 / 0.5 / 1 / 2			
Metric equivalents (1 N=0.10197 kg)	kg	20.4 / 51 / 102 / 204			
Rated Output (=RO)	mV/V	2 ± 0.1%			
Calibration in mV/V/Ω (A...I classified)	%RO	≤ ± 0.05 (≤ ± 0.005)			
Accuracy class according to OIML R 60		(GP)	C1	C3	C3 MR
Maximum number of verification intervals (n)		n.a.	1000	3000	3000
Minimum load cell verification interval (v _{min})		n.a.	E _{max} /5000	E _{max} /10000	E _{max} /20000
Combined error	%RO	≤ ± 0.040	≤ ± 0.030	≤ ± 0.020	≤ ± 0.020
Creep error (30 minutes)	%RO	≤ ± 0.060	≤ ± 0.049	≤ ± 0.024	≤ ± 0.024
Temperature effect on minimum dead load output	%RO/°C	≤ ± 0.0040	≤ ± 0.0028	≤ ± 0.0012	≤ ± 0.0007
Temperature effect on sensitivity	%/°C	≤ ± 0.0020	≤ ± 0.0016	≤ ± 0.0011	≤ ± 0.0011
Excitation voltage	V	5...15			
Zero balance	%RO	≤ ± 1.0			
Input resistance	Ω	1106 ± 5			
Output resistance	Ω	1000 ± 1			
Insulation resistance	MΩ	≥ 5000			
Compensated temperature range	°C	-10...+40			
Operating temperature range	°C	-40...+80			
Safe load limit	%E _{max}	200			
Ultimate load	%E _{max}	300			
Safe side load	%E _{max}	100			
Load cell material		stainless steel 17-4 PH (1.4548)			
Sealing		complete hermetic sealing; cable entry sealed by glass to metal header			
Protection according to DIN 40.050		IP 68			

Dimensions

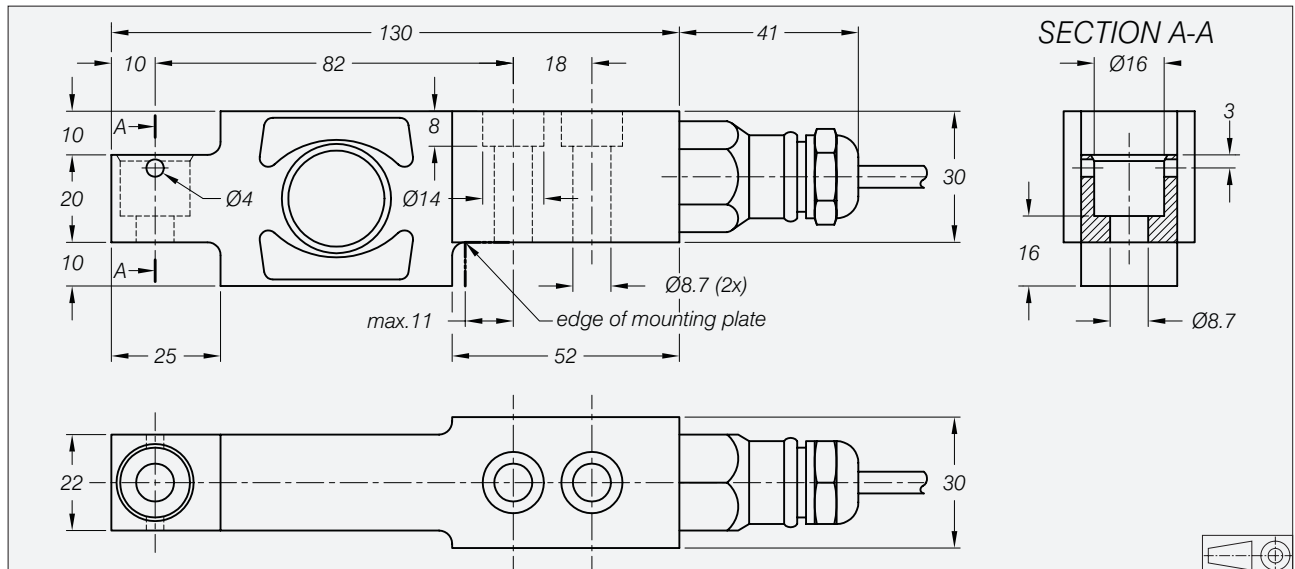

All dimensions in mm. Dimensions and specifications are subject to change without notice.

Note:

- Mounting bolts M8 8.8; torque: 25 Nm.

Wiring

- The load cell is provided with a shielded, 4 conductor cable.
- Cable length: 3 m.
- Cable diameter: 5 mm.
- The shield is floating.

